

NOVECENTO

design Claudio Bitetti 2009

Novecento mette a confronto una delle icone più significative del secolo scorso con una delle correnti artistiche più esemplari dello stesso. Abat-jour e Ready-made: l'oggetto e la sua trasformazione in qualcos'altro. Novecento nasce da un'ispirazione che raccoglie una tradizione e la trasforma con ironia.

Materiale: vasi in ceramica bianca e oro, diffusori in tessuto bianco e tecnopolimero oro. Struttura: metallo.

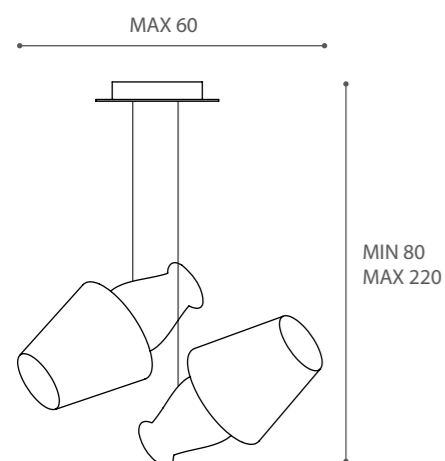

Novecento compares one of the most significant icons of the last century with one of the most considerable artistic currents of the same one that are Abat-jour and Ready-made: the object and its transformation in something else. Novecento borns from an inspiration that collects a tradition and transform it with irony. Material: white and gold ceramic pots, white fabric shades and gold technopolymer. Metal structure.

C1

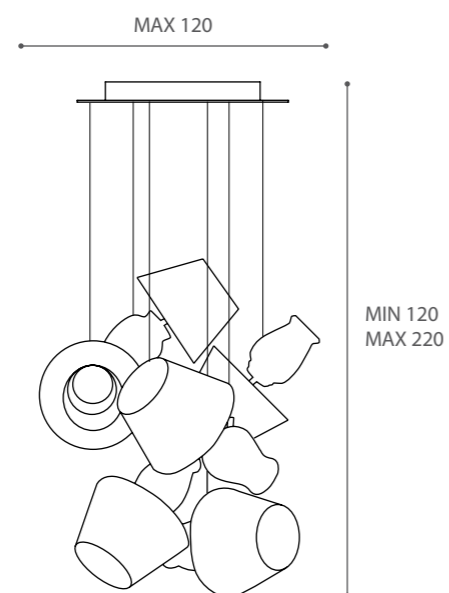

C2



C1 2x LED E27 20W 2500lm (5000lm)   

C2 6x LED E27 20W 2500lm (15000lm) 